



*An Online PDH Course
brought to you by
CEDengineering.com*

Introduction to Water Distribution in Cold Regions

Course No: C02-044
Credit: 2 PDH

J. Paul Guyer, P.E., R.A., Fellow ASCE, Fellow AEI



Continuing Education and Development, Inc.
22 Stonewall Court
Woodcliff Lake, NJ 07677

P: (877) 322-5800
info@cedengineering.com

CONTENTS

- 1. GENERAL**
- 2. SINGLE PIPE RECIRCULATION SYSTEM**
- 3. ALTERNATIVE SYSTEMS**
- 4. SERVICE LINES**
- 5. MATERIALS**
- 6. APPURTENANCES**
- 7. BACKUP FREEZE PROTECTION**

1. GENERAL. This publication presents information that is unique to the Arctic or Subarctic. Pressurized, pipe distribution systems are used for exterior utilities and interior plumbing in most facilities in the cold regions. An exception might be small facilities at locations remote from the main distribution network. If individual wells are not feasible, then vehicle delivery of water would be necessary. Truck delivery systems are common at remote civilian communities in Alaska, Canada and Greenland. Vehicle specifications for this special purpose can be obtained from the U.S. Public Health Service-Indian Health Service, 701 C St., Box 65, Anchorage, Alaska 99513.

2. SINGLE PIPE RECIRCULATION SYSTEM. The single pipe recirculation system is recommended for arctic conditions. As shown in Figure 1, it consists of one or more uninterrupted loops originating at a recirculation facility and returning to that point without any branch loops. This layout will eliminate dead ends and related freezing problems and requires the minimum amount of piping as compared to other circulation methods. A simple, positive control of distribution is possible with flow and temperature indicators on the return lines at the recirculation facility. Normally water is pumped out at between 39 and 45 degrees F and returns at 33 to 39 degrees F. Pipe network design uses the same procedures used for standard water systems. The return line does not have to be of the same size as the delivery pipe because of withdrawals in the network. Expansion of the system is provided by the construction of temporary links to close the loops at the end of the present system when the system is expanded, the link is valved off and the pipe link left empty. If possible, the mains will be located at the rear of buildings, rather than in the streets, as shown in Figure 1. This will provide greater thermal protection (since snow is not typically removed), result in less risk of damage to manholes and other appurtenances, and allow shorter, less costly service connections to the buildings. There are special advantages to this approach for housing areas where large numbers of similar structures tend to be laid out in a regular pattern.

3. ALTERNATIVE SYSTEMS. Conventional water pipe mains with no recirculation are possible in very special situations, but require careful planning in the initial site layout for installations. In these cases, there may be enough flow in the system so that return loops are not needed if a high volume consumer is placed at the ends of the main line. Sizing of the pipe network and other design details follow conventional practice. A dual pipe system relies on a large diameter supply line and a small diameter return line placed side by side in a utilidor or a preinsulated conduit as shown in Figure 2. The return line is sized to maintain the desired flow in the system. Figure 3 is a schematic illustration of typical service connections from a dual system. The service lines are taken off the main and returned to the smaller diameter return line.

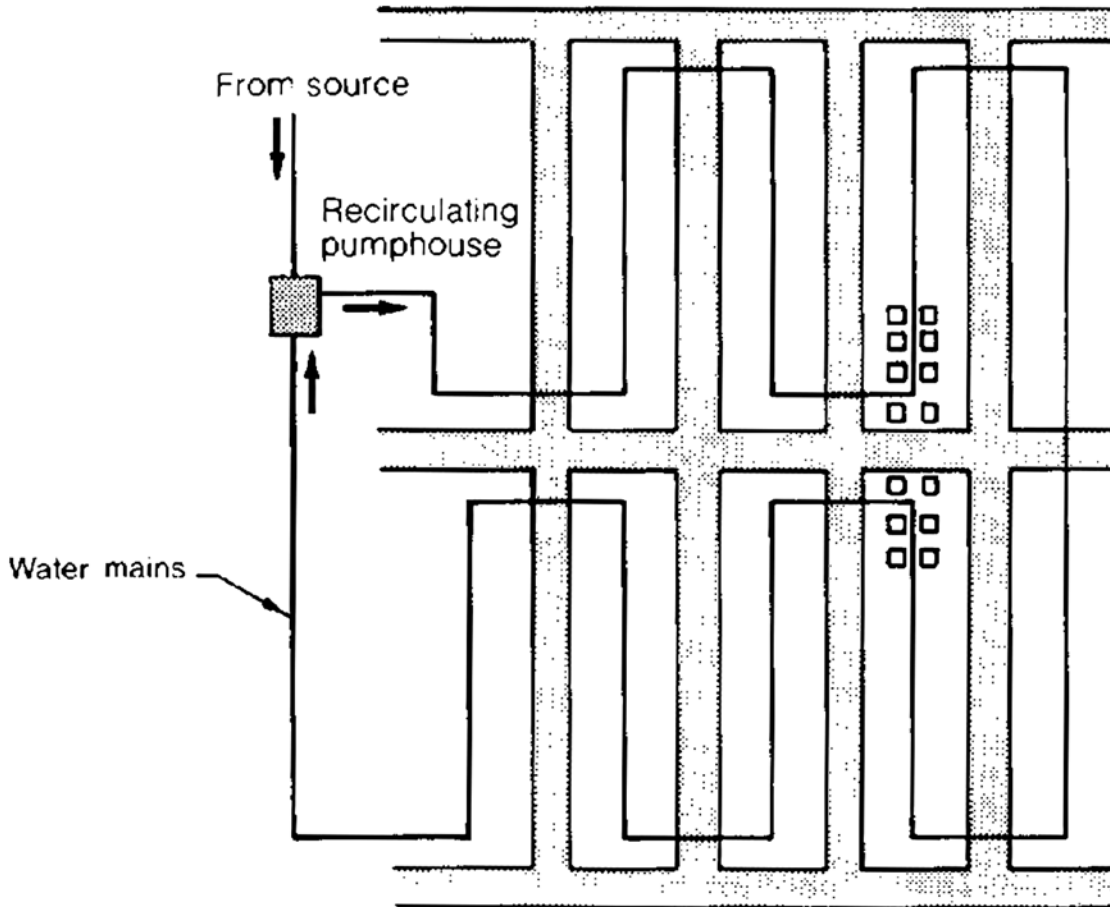

Figure 1
Layout and location of mains for single pipe recirculation

The pressure differential between the delivery and the return line must be sufficient to induce circulation in the service loop. The system is complex and control mechanisms tend to be elaborate. For example, varying consumption in different locations can result in stationary water in areas at certain times. As shown in Figure 3, thermostatically controlled solenoid valves are used at regular intervals to overcome this problem. Some facilities have utilized seasonal transmission mains to convey the water from a summer source to storage tanks. Such lines do not need special thermal considerations.

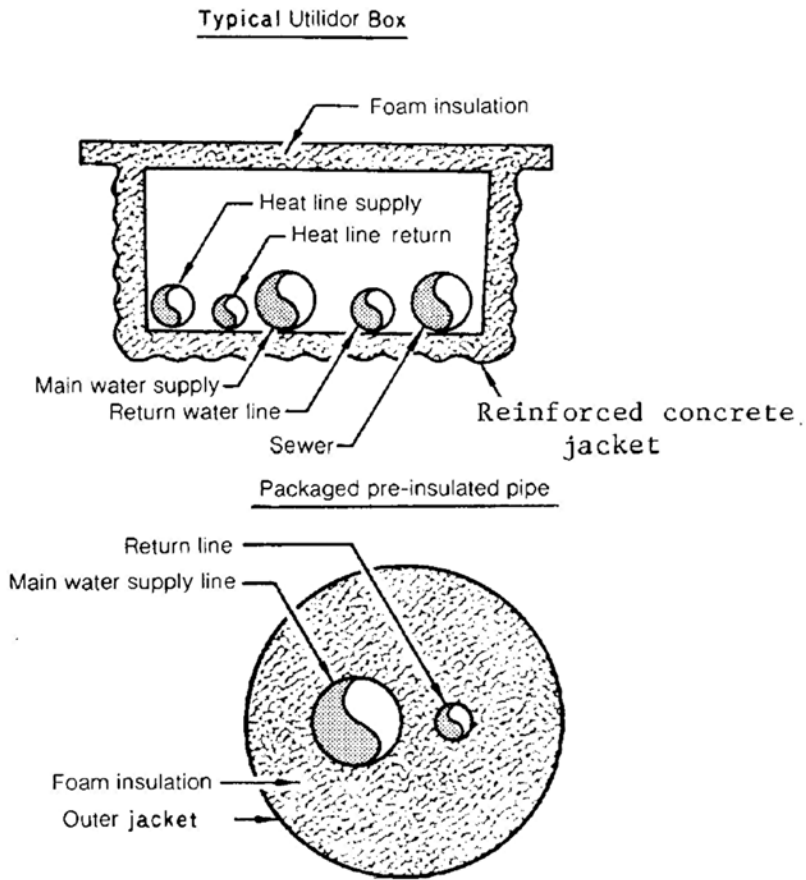

Figure 2
Typical utilidor and packaged preinsulated pipe

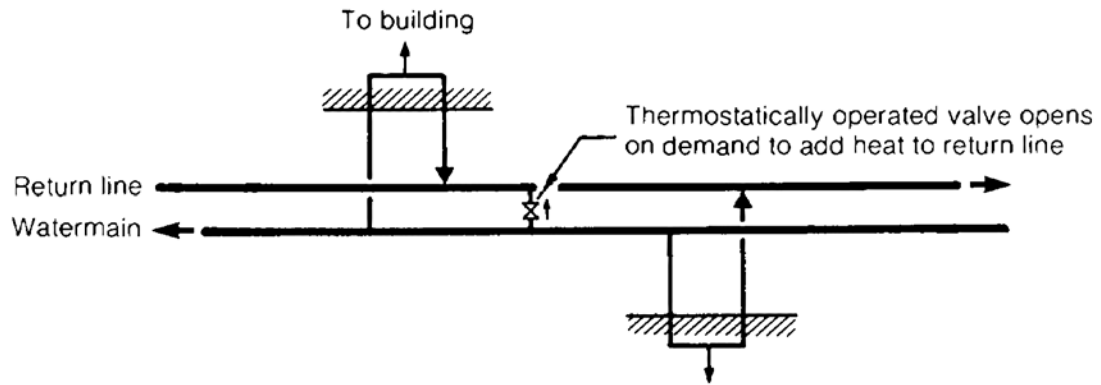

Figure 3
Schematic diagram of a dual pipe system

4. SERVICE LINES. The design of service lines must prevent freezing of the contained water but must also consider the effects of permafrost thawing, frost heaving and differential settlements between the pipes and the building. Circulation in these service connections is the recommended method to prevent freezing. Heat tapes are also commonly installed as a backup. The two most common methods for circulation are either a small pump inside the building or the use of pit orifices. A typical pit orifice installation is shown in Figure 4. There will be a small velocity-induced pressure differential between the upstream and downstream orifices, which in turn induces flow in the service loop. To operate properly, the flow velocity in the main must be at least 2 feet per second and this can be technically difficult and energy intensive for large diameter water mains. If the service lines are longer than 80 feet, the pressure differential in the main is not sufficient and the pit orifice will not function. A small circulation pump must be added in the building for longer distances. The presence of these pit orifices will result in head losses in the main. A head loss of about 0.2 feet per service connection is suggested as a conservative design value. The head losses in the plumbing in the pumphouses used for circulating water in the mains must also be considered as they are substantial on most systems. Backup freeze protection is usually provided by a thermostatically controlled electrical heat tracer. If copper pipe is used for the service lines, an electrical connection between the two service pipes at the main will allow electrical resistance thawing from within the building as a second backup system. Figure 4 illustrates both of these approaches. Typical details of above-ground service lines and connections are shown in Figures 5 and 6. Figure 7 illustrates the details of an underground valve and box on water mains. The valve box assembly should be packed with a low temperature non-hardening grease to prevent infiltration and freezing of water around the mechanism in the winter. A pair of adjacent buildings can employ a common service loop as shown in Figure 8. This will be less expensive than individual service connections and will be more reliable because of the two circulation pumps on the single loop.

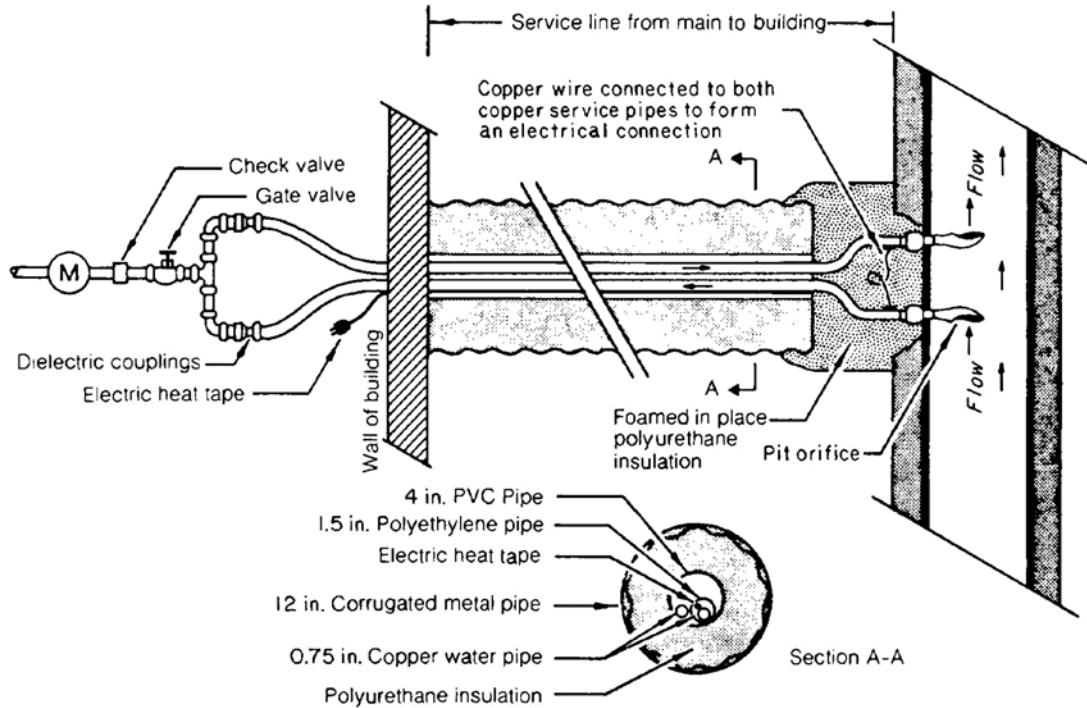

Figure 4
Water service line, with pit orifices

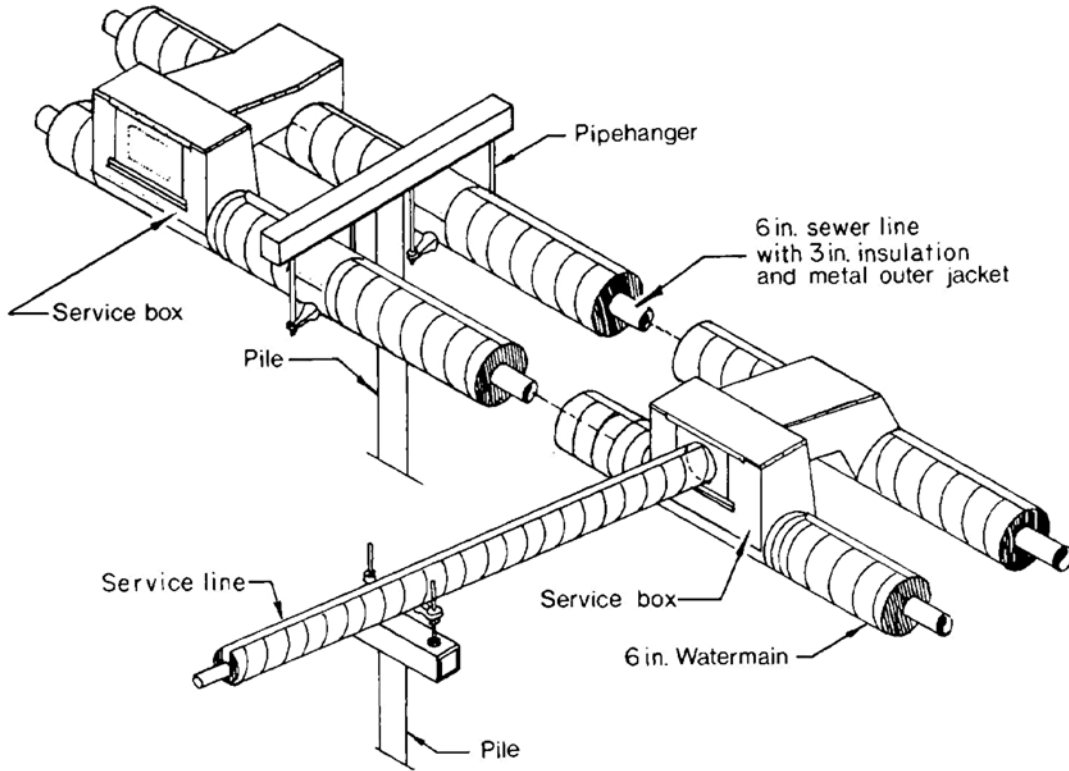

Figure 5

Typical above-ground service line takeoffs

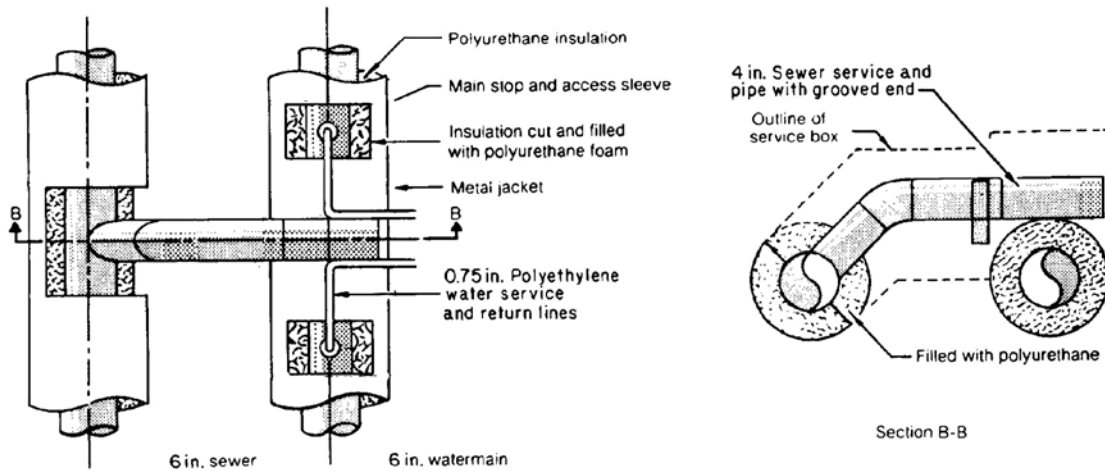

Figure 6

Typical above-ground service line

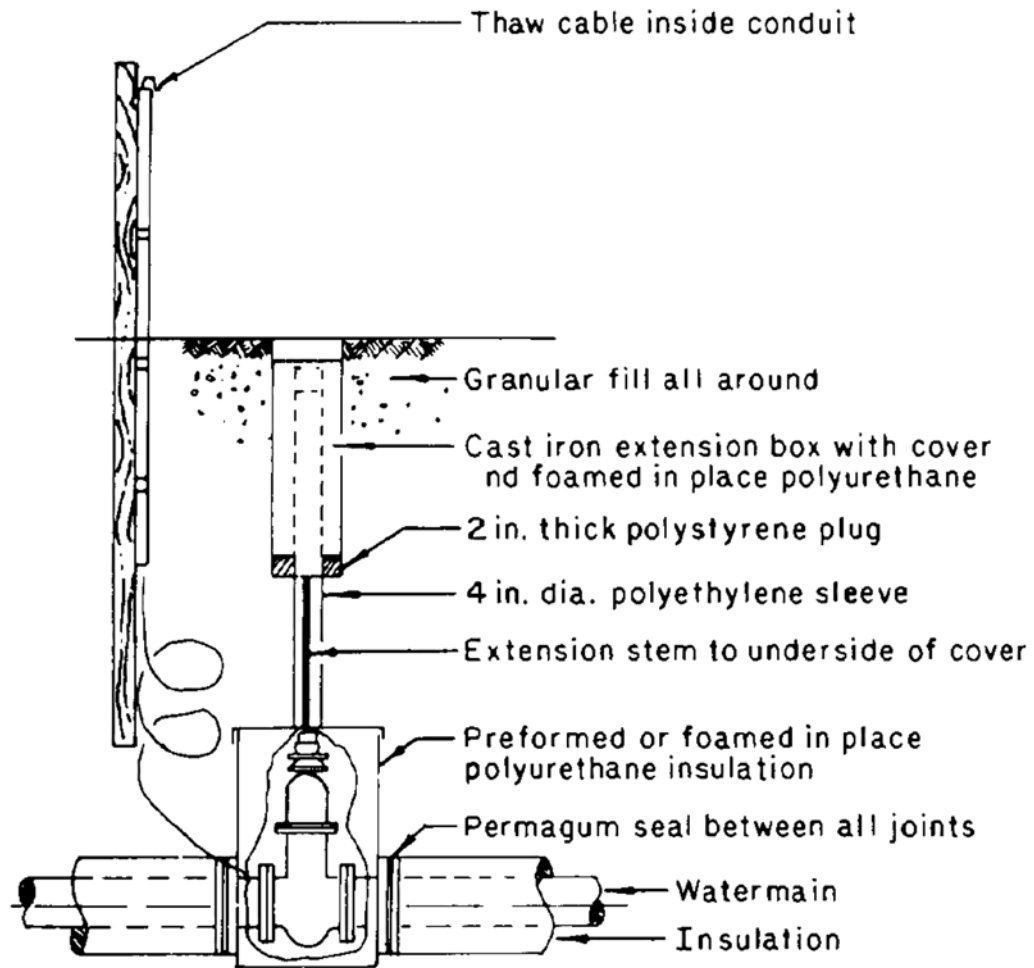

Figure 7
Underground valve and box

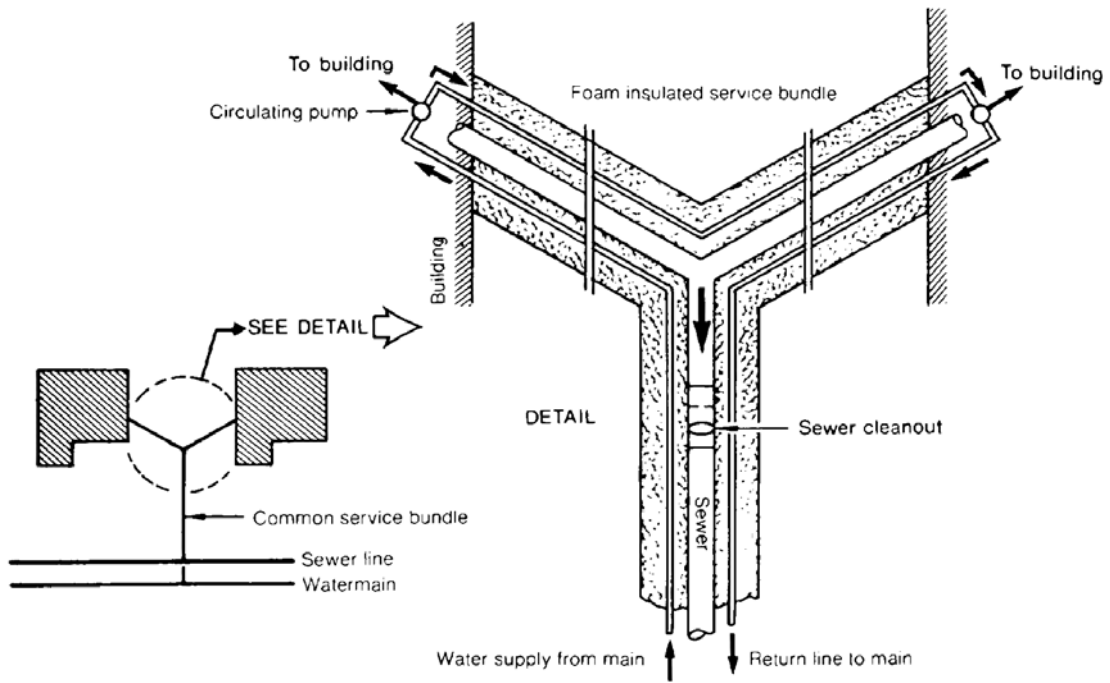

Figure 8
Dual service

5. MATERIALS. The basic selection of pipe materials will be in accordance with the professional literature. The discussion that follows is intended to give some indication of the performance of these materials in the Arctic and Subarctic.

5.1 COPPER. Type K copper is commonly used for service lines because it can be thawed by using electrical resistance while plastic pipes cannot be thawed in this manner.

5.2 DUCTILE IRON. Ductile iron pipe can take some shock loadings and is slightly flexible. It has poor corrosion resistance and lining is necessary. It is a heavy, durable pipe often used in rocky areas or where adequate pipe bedding materials are not available. Ductile iron pipe with special joints is used where bridge strength is required to span piles or where differential settlements are anticipated in buried systems. It can be thawed with electrical resistance.

5.3 STEEL PIPE. Steel pipe is lighter, more flexible, and more corrosion resistant than ductile iron. Continuously welded steel pipe has been used to obtain maximum span between piles. It can also be thawed using electrical resistance. Expansion and contraction, including necessary thrust anchors, must be considered. The differential expansion and contraction between a steel pipe and rigid heat tracing components or insulations attached to the pipe must also be considered.

5.4 HIGH DENSITY POLYETHELENE (PE). Pipe of this material is very flexible and impact resistant, with a high coefficient of expansion and contraction, high corrosion resistance and a smooth interior, but it cannot be threaded. Butt-fused polyethelene pipe has been used extensively in Canada for water and sewer mains. Typically the water pipe is insulated with urethane and then covered with a thin polyethylene jacket. Field joints are insulated and covered with heat shrink couplings. The most common use has been in buried systems, and experience has shown that the pipe and contained water can freeze solid without breaking the line.

5.5 POLYVINYL CHLORIDE (PVC). This is the most common type of plastic pipe used for water mains. It can be threaded, is corrosion resistant and has a smooth interior but is not as flexible as PE, and may rupture if pipe and contents freeze. As a result PVC pipe is not the best choice for single pipe systems buried in permafrost areas.

5.6 ACRYLONRILE-BUTADIENE-STYRENE (ABS). This pipe has a higher impact strength and flexibility but a lower mechanical strength than PVC. It has a smooth interior and does not become brittle at cold temperatures. ABS pipe has mostly been used for non-pressure drainage, sewer and vent piping. It is not recommended for single pipe systems buried in permafrost areas.

5.7 ASBESTOS-CEMENT (AC). This pipe is relatively inexpensive, light weight, corrosion resistant and has a smooth interior. However, it is brittle and is not suited for buried installations in the Arctic or Subarctic where differential settlements and frost heaving are expected.

5.8 OTHERS. Reinforced concrete is usually used for large transmission lines. Wood stave piping has been successfully used in the past. It is corrosion free, has a smooth interior and can usually be restored after a freezing event, but cannot be thawed electrically.

5.9 INSULATION. Pipe units composed of the materials (except wood and concrete) described above are typically insulated with high density urethane foam at the factory and covered with either a steel or a 40-mil high density polyethelene jacket, depending on the final conditions of exposure in the field. Design calculations to determine insulation thickness are required. These prefabricated pipe units are then shipped to the job site with preformed half shells of urethane insulation for the joints. Heat shrink sleeves or special tape is used to complete the field joint when PE is used as the outer jacket. Prefabricated sections are used for steel-jacketed pipes. Pipe insulation is not normally done on-site because of high costs and labor. Factory prefabrication will

usually ensure better quality insulation. Exceptions are appurtenances such as hydrants where foamed-in-place urethanes are commonly employed.

6. APPURTENANCES. On a typical water distribution system these include hydrants and valves.

6.1 HYDRANTS. Figure 9 illustrates the typical details of a hydrant installed on an above-ground water main. The insulated hydrant box must be specially designed and fabricated to fit the equipment to be used and the particular location. The riser from the main to the hydrant base will be as short as possible so that heat conducted from the water flowing in the main can keep the hydrant from freezing. A typical hydrant connection to a buried water main is shown in Figure 10. The hydrant is normally on-line to minimize the possibility of freezing, with a frost-isolating gasket between the hydrant barrel and the tee into the main. The hydrant barrel is insulated with 3-inch prefabricated polyurethane inside a polyethylene sleeve. The annulus between the sleeve and the insulated barrel is filled with an oil and wax mixture to prevent frost heave damage. Isolating valves are typically put in the main or both sides of the tee to allow for hydrant repair or replacement. After use the hydrant must be pumped out since frozen ground conditions may prevent self-drainage.

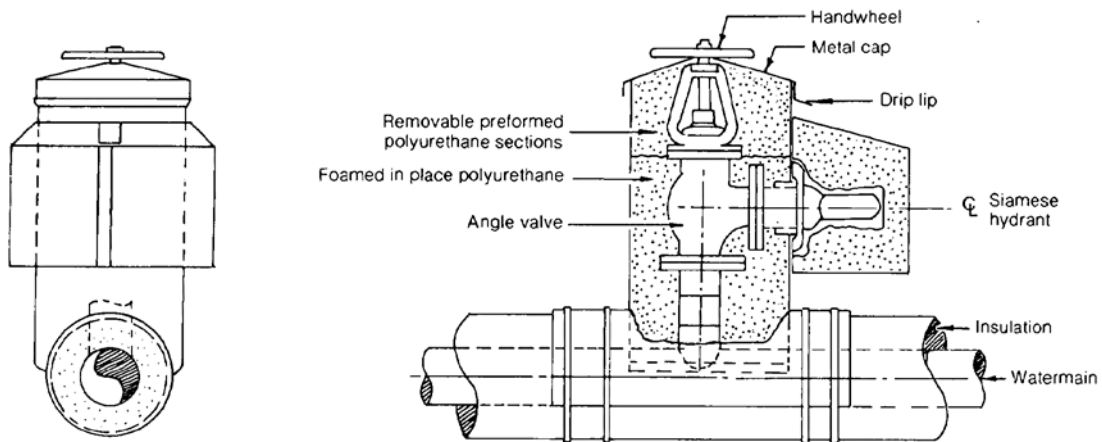

Figure 9
Above-ground hydrant

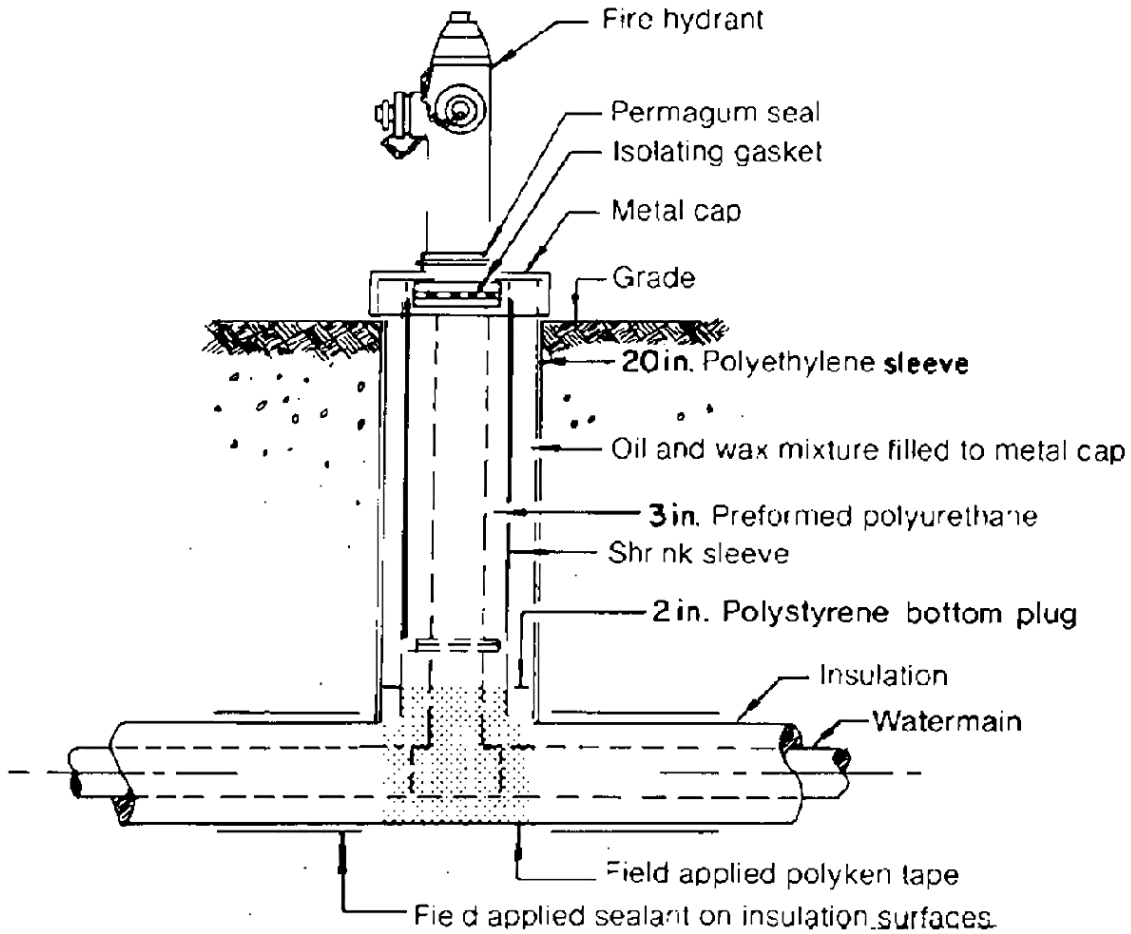

Figure 10

Below-ground hydrant

6.2 VALVES. Typical details for valve installations are shown in Figures 5 and 7. The riser stem for buried valves is insulated in a manner similar to that described above for hydrants. Non-rising stem-gate valves are most practical for buried or completely insulated locations.

7. BACKUP FREEZE PROTECTION.

These are reserve systems to either prevent freezing if circulation stops in the lines or to thaw the system if freezing occurs. The procedures apply to both main lines and service piping. These include electrical heat or steam tracing to prevent freezing or to thaw, and electrical resistance heating and steam or hot water to thaw systems.

7.1 HEAT TRACE SYSTEMS. A heat trace system is the standard back-up used in most piped water distribution systems. While it is effective, both the initial capital cost and operating cost for this type of protection are substantial. Constant monitoring must be carried out on such electrical systems if they are to perform as intended. If the controlling thermostats are not working properly or the sensing bulbs are in the wrong location, either too much electric energy will be expended at great cost or it will fail to do the job when required. Easy replacement of heat trace lines should be a standard feature of any system. The heat trace normally used is the constant watt per foot type placed in a conduit or channel next to the pipe with or without heat contact cement. Common wattages used are 2.5 watts per foot for service lines and 4 watts per foot for main lines. This method is less efficient on plastic piping. In Greenland and northern Scandinavia the heat trace is placed inside plastic pipes. Calculations can be used to determine heat tracing design requirements.

7.2 STEAM OR HOT WATER THAWING. This system uses a source of steam, such as a portable steam jenny, or hot water introduced under pressure into the frozen pipe via a suitable hose or tube to thaw out the pipe. This system can be used with most types of pipe materials. It is not recommended for plastic which could melt or be damaged if the procedure used is improper.

7.3 SERVICE LINE THAWING. Small-diameter service lines of any material may be quickly thawed by pushing a flexible 0.5 in. or smaller, plastic tube into the frozen pipe while pumping warm water into the tube. Water pressure can be obtained from a nearby building, either directly or by connecting to the building plumbing. A conventional hand pump filled with warm water can also be used (Fig. 11). A commercial unit produces a

pulsating stream of water to pump warm water through a tube attached to the frozen pipe by a special fitting to ease the installation and reduce spillage.

7.4 ELECTRICAL RESISTANCE THAWING. The thawing of metal pipes using electricity is fairly common. Either portable gasoline or diesel generators, welders, or heavy service electrical transformers (110 or 220 volt) have been used (Fig. 12). AC or DC current at high amperage and very low voltage (seldom more than 15 volts) can be used. The amount of heat generated when current is passed through a pipe is:

$$W = I^2 R$$

where

W = heat or power in watts (or joules per second)

I = current in amps

R = resistance in ohms

The rate of thawing of a frozen pipe is directly proportional to the square of the current applied, the mass of the pipe (cross-sectional area times length), and the material's effective resistance to the passage of electricity. For example, doubling the current (I) will increase the heat generated by a factor of four. Generally, as much current (heat) as practical, with safety limits, must be provided so that the thawing time is reduced. The approximate times required to thaw different sizes of steel pipe using different currents are given in Figure 13. Copper pipe has about one-ninth the resistance of steel and a smaller cross-sectional area. Therefore, when thawing copper pipes, these current values must be increased by about 10 percent for 1/2-inch pipe, 25 percent for 1-inch pipe, and higher values for larger copper pipes. However, when copper pipe with soldered joints is to be thawed, it must not be heated to the point where the solder melts (silver solder can be used to alleviate this). Steel lines with continuous joints can be expeditiously thawed with welders. The following precautions must be taken when thawing pipes electrically:

- (1) Use on underground or protected pipe only (not indoor plumbing).

- (2) Don't use a high voltage. Twenty volts with 50 to 60 amps is sufficient. (Do not use a constant voltage power source because there is usually no control for limiting the current.)
- (3) Make good, tight connections to the pipeline.
- (4) When conventional arc welders are used for thawing, do not operate them at their maximum rated amperage for more than five minutes. Only use about 75% of rated amperage if longer times are needed.
- (5) Disconnect electrical wires grounded to the water pipes in the buildings, or disconnect the service pipe from the house plumbing. Failure to do this could cause fire.
- (6) Remove meters that may be in the service line.
- (7) A problem may be encountered with the thawing current jumping from the water service line into nearby gas or other lines. These should be separated by a 1-inch wood block or wedge.

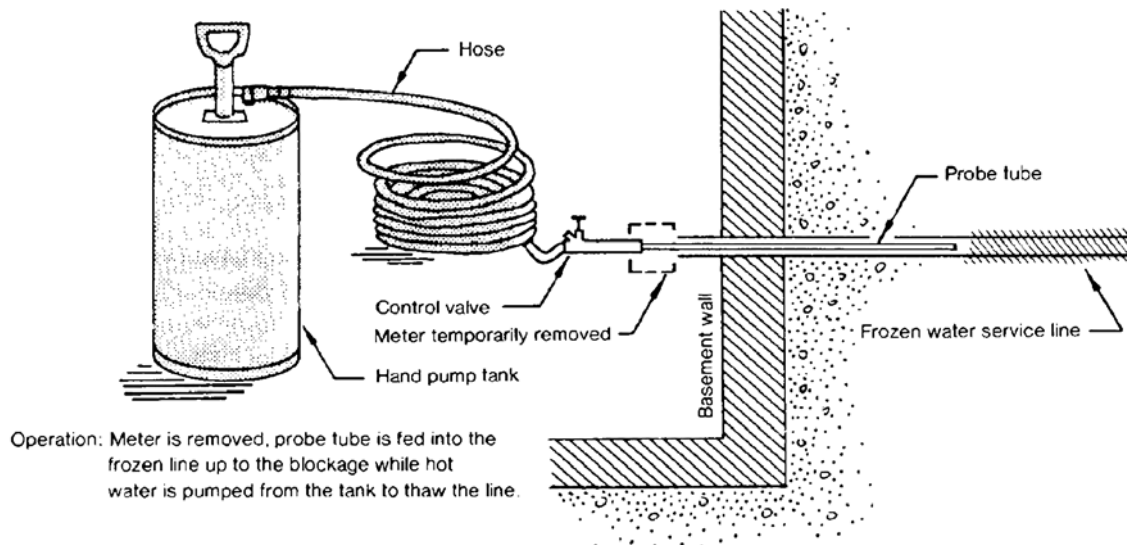

Figure 11
Thaw tube, thawing method

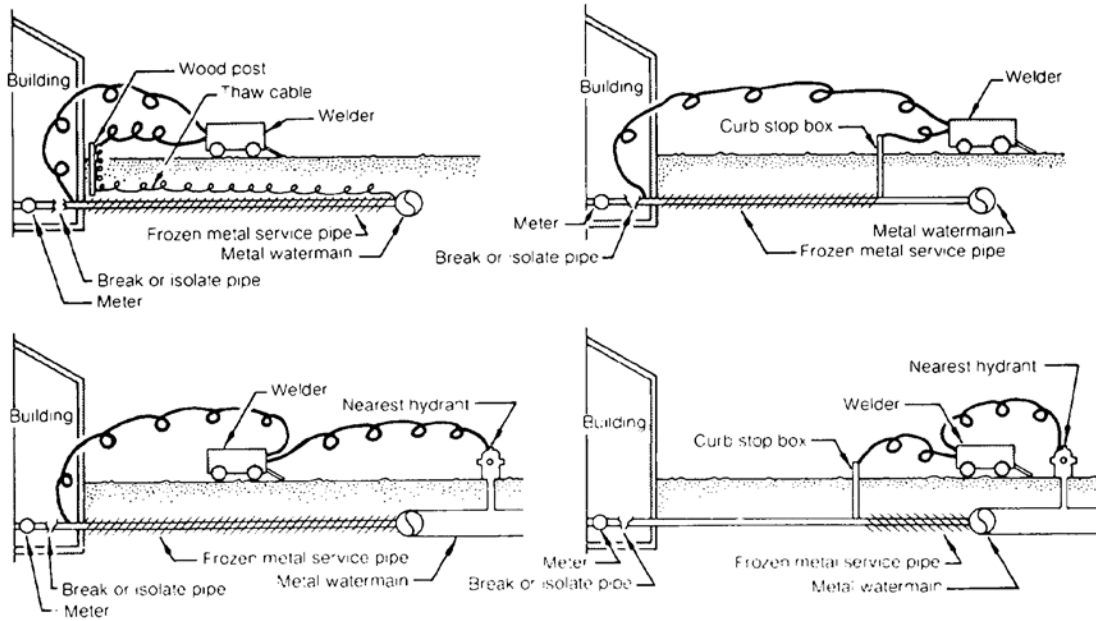

Figure 12
Alternatives for thawing service lines

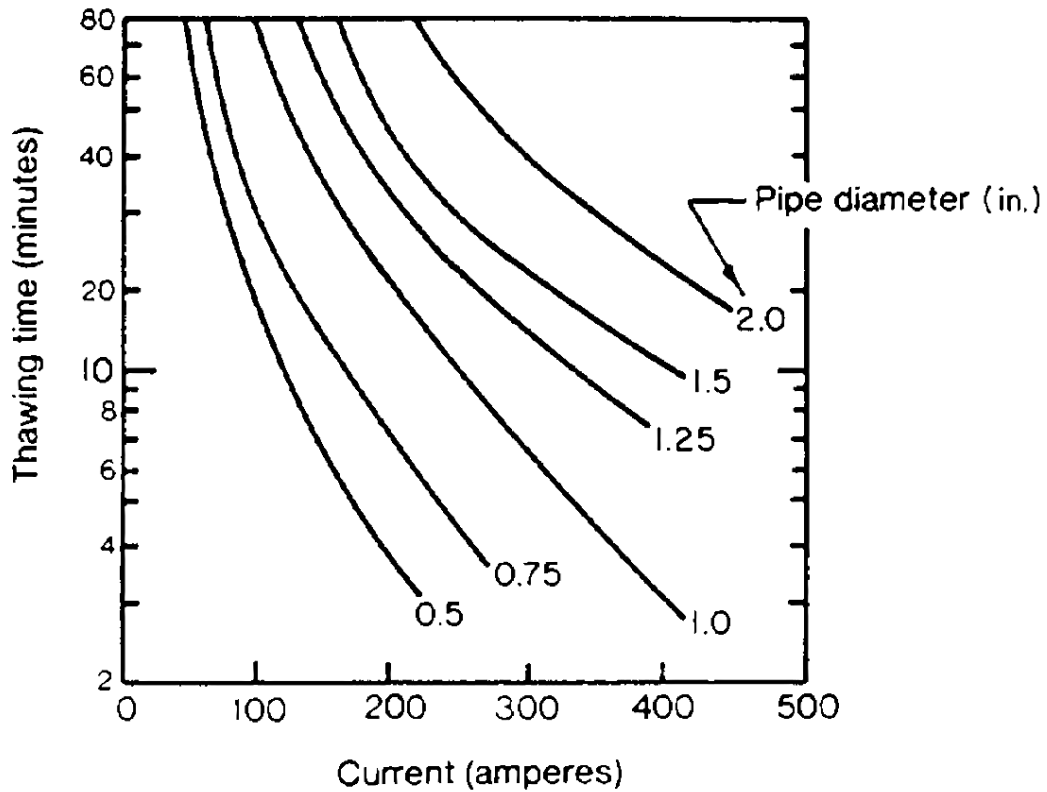

Figure 13
Approximate times and current for thawing steel pipes